



SERVICE DATA

TRIMMER/BRUSHCUTTER

SRM-330ES

SRM-350ES

(Serial number : 36000001 and after)

INTRODUCTION

We are constantly working on technical improvement of our products. For this reason, technical data, equipment and design are subject to change without notice. All specifications, illustrations and directions in this SERVICE DATA are based on the latest products information available at the time of publication.

ECHO SERVICE MANUAL Ord. 402-25 (Model : SRM-4000, RM-4000) contains lots of information for servicing this model.

CONTENTS

	page
1 SERVICE INFORMATION	2
1-1 Specification	2
1-2 Technical data	3
1-3 Torque limits	4
1-4 Special repairing materials	4
1-5 Service limits	5
1-6 Special tools	6
2 EMISSION ADJUSTMENT GUIDE	7
2-1 General adjusting rules	7
2-2 Presetting idle adjust screw and idle mixture needle	7
2-3 Adjusting carburettor	8



KIORITZ CORPORATION

Reference No. **10-311-01**

REVISED: 200502

ISSUED: 200407

1 SERVICE INFORMATION

1-1 Specifications

Model		SRM-330ES (L)	SRM-330ES (U)	SRM-350ES (L)	SRM-350ES (U)	
Dimensions	Length*	mm(in)	1825 (71.9)	1830 (72.0)	1825 (71.9)	1830 (72.0)
	Width	mm(in)	320 (12.6)	670 (26.3)	320 (12.6)	670 (26.3)
	Height	mm(in)	275 (10.8)	473 (18.6)	275 (11.9)	473 (18.6)
Dry weight**		kg(lb)	7.1 (15.7)	7.2 (15.9)	7.1 (15.7)	7.2 (15.9)
Engine	Type	KIORITZ, air-cooled, two-stroke, single cylinder Semi-automatic decompression				
	Rotation	Anticlockwise as viewed from the output end				
	Displacement	cm ³ (in ³)	30.5 (1.861)		34.0 (2.075)	
	Bore	mm(in)	36.0 (1.417)		38.0 (1.496)	
	Stroke	mm(in)	30.0 (1.181)		30.0 (1.181)	
	Compression ratio	6.9 : 1				
Carburettor	Type	Rotary type : Diaphragm, horizontal-draught, with primer (purge pump)				
	Model	Walbro WYJ-312A		Walbro WYJ-373A		
	Venturi size-Throttle bore	mm(in)	12.2 - 12.2 (0.48 - 0.48)		10.5 - 10.5 (0.41 - 0.41)	
Ignition	Type	TCI (Transistor controlled ignition) system in a single integrated piece				
	Spark plug	BPMR7A				
Starter	Type	ES (Effortless)- start				
	Rope diameter x length	mm(in)	3.8 x 1000 (0.15 x 39.8)			
Fuel	Petrol	Minimum 89 octane petrol (RON)				
	Two-stroke engine oil	ISO-L-EGD (ISO/CD13738), JASO FC				
	Tank capacity	L (U.S.fl.oz.)	0.84 (28.4)			
Clutch	Type	Centrifugal, 2 - shoe pivot				
Handle	Type	Front	Crescent loop w/cushion grip	U-shaped	Crescent loop w/cushion grip	U-shaped
		Rear	Integrated control grip w/cushion	- - -	Integrated control grip w/cushion	- - -
Drive shaft	Type	Solid				
	Diameter - Length	mm(in)	8 - 1590 (0.31 - 62.6)			
	Housing	OD -ID	28 - 24 (1.10 -0.94)			
	(Main pipe)	Length	1530 (60.2)			
Gear case	Reduction ratio	1.33				
	Gear tooth	Spiral bevel gear				
	Lubrication	Lithium based grease				
Cutter	Type	Nylon line cutter, 3-tooth blade [†] , Others				
	Pilot diameter	mm(in)	25.4 (1.0)			
	Fastener type, size	mm	Left-hand thread nut, M10 x 1.25 pitch			
	Cutting rotation	Anticlockwise as viewed from top				

OD: Outer diameter.

ID: Inner diameter.

* Without shoulder harness and cutter head.

** With standard cutter head, without shoulder harness.

[†] Install and use U-shaped handle when operating with steel blade.

1-2 Technical data

Model		SRM-330ES	SRM-350ES
Engine			
Idling speed	r/min	2300 - 3300	
Operating speed	r/min	6500 - 7500	
Clutch engagement speed	r/min	3600 - 4200	
Compression pressure	MPa (kgf/cm ²) (psi)	1.05 (10.5) (150)	0.95 (9.5) (135)
Ignition system			
Spark plug gap	mm (in)	0.6 - 0.7 (0.024 - 0.028)	
Minimum secondary voltage at 1000 r/min	kV	17	
Secondary coil resistance	kΩ	11 - 15	
Pole shoe air gaps	mm(in)	0.3 - 0.5 (0.012 - 0.020)	
Ignition timing at 1000 r/min	°BTDC	25	
Carburettor			
Main jet		#44	#38
Idle adjust screw initial setting	turn in*	4 1/2	4 1/2
Idle mixture needle initial setting	turns in**	14	14
Test pressure, minimum	MPa (kgf/cm ²) (psi)	0.05 (0.5) (7.0)	
Metering lever height	mm (in)	1.5 (0.06) lower than diaphragm seat	

BTDC: Before top dead centre.

* Set idle speed screw to contact throttle plate before initial setting.

** Screw in idle mixture needle from initial thread engagement (at the point that the clicking sound is heard).

1-3 Torque limits

Descriptions		Size	kgf•cm	N•m	in•lbf	
Starter system	Pawl carrier	M 8	80 - 100	8 - 10	70 - 90	
	Pawl carrier nut	M 8	160 - 200	16 - 20	140 - 175	
	Starter case	Tops	M 5*	30 - 45	3.0 - 4.5	26 - 40
		Bottoms	M 5	50 - 80	5 - 8	45 - 70
Ignition system	Magneto rotor (Flywheel)	M 8	180 - 230	18 - 23	155 - 200	
	Ignition coil	M 5	70 - 90	7 - 9	60 - 80	
	Spark plug	M 14	150 - 170	15 - 17	130 - 150	
	Fan cover	M 5	70 - 110	7 - 11	60 - 95	
Fuel system	Carburettor insulator	M 5*	60 - 80	6 - 8	50 - 70	
	Carburettor	M 5	35 - 50	3.5 - 5.0	30 - 45	
	Fuel tank stand	M 5	50 - 80	5 - 8	45 - 70	
	Cleaner case	M 5*	30 - 45	3.0 - 4.5	26 - 40	
Clutch	Clutch shoe	M 8	70 - 110	7 - 11	60 - 95	
Engine	Crankcase	M 5**	70 - 110	7 - 11	60 - 95	
	Cylinder	M 5**	70 - 110	7 - 11	60 - 95	
	Cylinder cover	M 5*	30 - 45	3.0 - 4.5	26 - 40	
	Muffler	M 6	60 - 100	6 - 10	50 - 90	
	Muffler cover	M 5*	30 - 45	3.0 - 4.5	26 - 40	
	Muffler stay	M 5	60 - 90	6 - 9	50 - 80	
Others	Blade fastening nut	LM 10	280 - 320	28 - 32	245 - 280	
Regular bolt, nut, and screw		M 3	6 - 10	0.6 - 1.0	5 - 9	
		M 4	15 - 25	1.5 - 2.5	13 - 22	
		M 5	25 - 45	2.5 - 4.5	22 - 40	
		M 6	45 - 75	4.5 - 7.5	40 - 65	
		M 8	110 - 150	11 - 15	95 - 130	
		M 10	210 - 300	21 - 30	180 - 260	

LM: Left hand thread.

* Apply thread locking sealant. (See below)

** The torque differences among four bolts should not exceed 20 kgf•cm (2Nm, 17in•lbf) on one cylinder or crankcase.

1-4 Special repairing materials

Material	Location	Remarks
Grease	Gear case	Lithium based grease or ECHO LUBE™
	Rewind spring	
	Starter center post	
Oil	Oil seal inner lips	Two-stroke engine oil or engine oil (SAE#30)
	Drive shaft	
Thread locking sealant	Starter case	Loctite #242, ThreeBond #1324 or equivalent
	Cleaner case	
	Cylinder cover	
	Muffler cover	
	Carburettor insulator	Loctite #222, ThreeBond #1342 or equivalent

1-5 Service limits

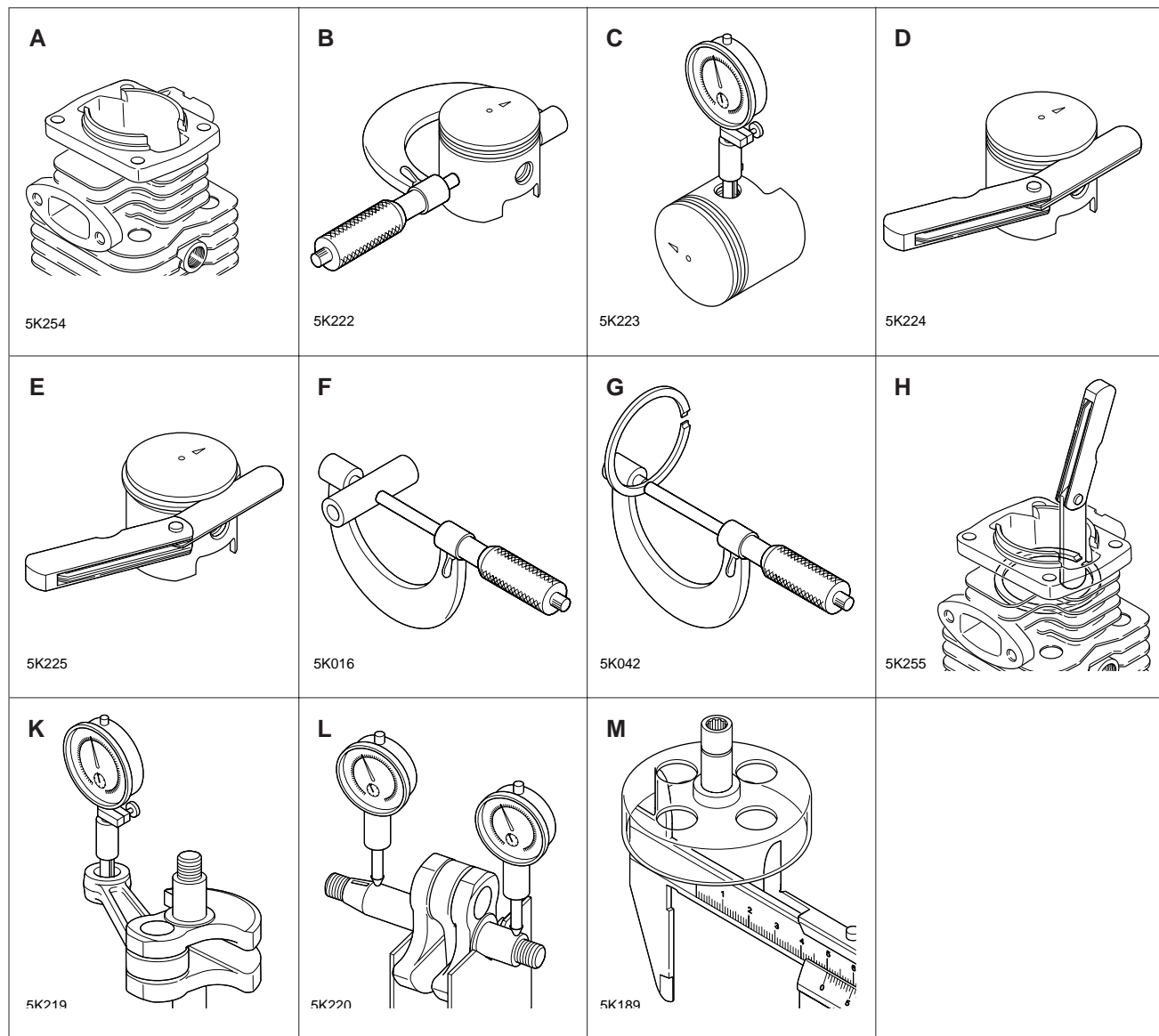

Description		mm (in)	
		SRM-330ES	SRM-350ES
A	Cylinder bore	When plating is worn and aluminium can be seen	
B	Piston outer diameter	Min. 35.90 (1.413)	37.90 (1.491)
C	Piston pin bore	Max. 9.03 (0.355)	9.03 (0.355)
D	Piston ring groove	Max. 1.55 (0.061)	1.3 (0.051)
E	Piston ring side clearance	Max. 0.05 (0.002)	0.1 (0.004)
F	Piston pin outer diameter	Min. 8.98 (0.354)	8.98 (0.354)
G	Piston ring width	Min. 1.45 (0.057)	1.15 (0.045)
H	Piston ring end gap	Max. 0.5 (0.02)	0.5 (0.02)
K	Con-rod small end bore	Max. 12.03 (0.473)	12.03 (0.473)
L	Crankshaft runout	Max. 0.05 (0.002)	0.05 (0.002)
M	Clutch drum bore	Max. 71.5 (2.81)	71.5 (2.81)

1-6 Special tools

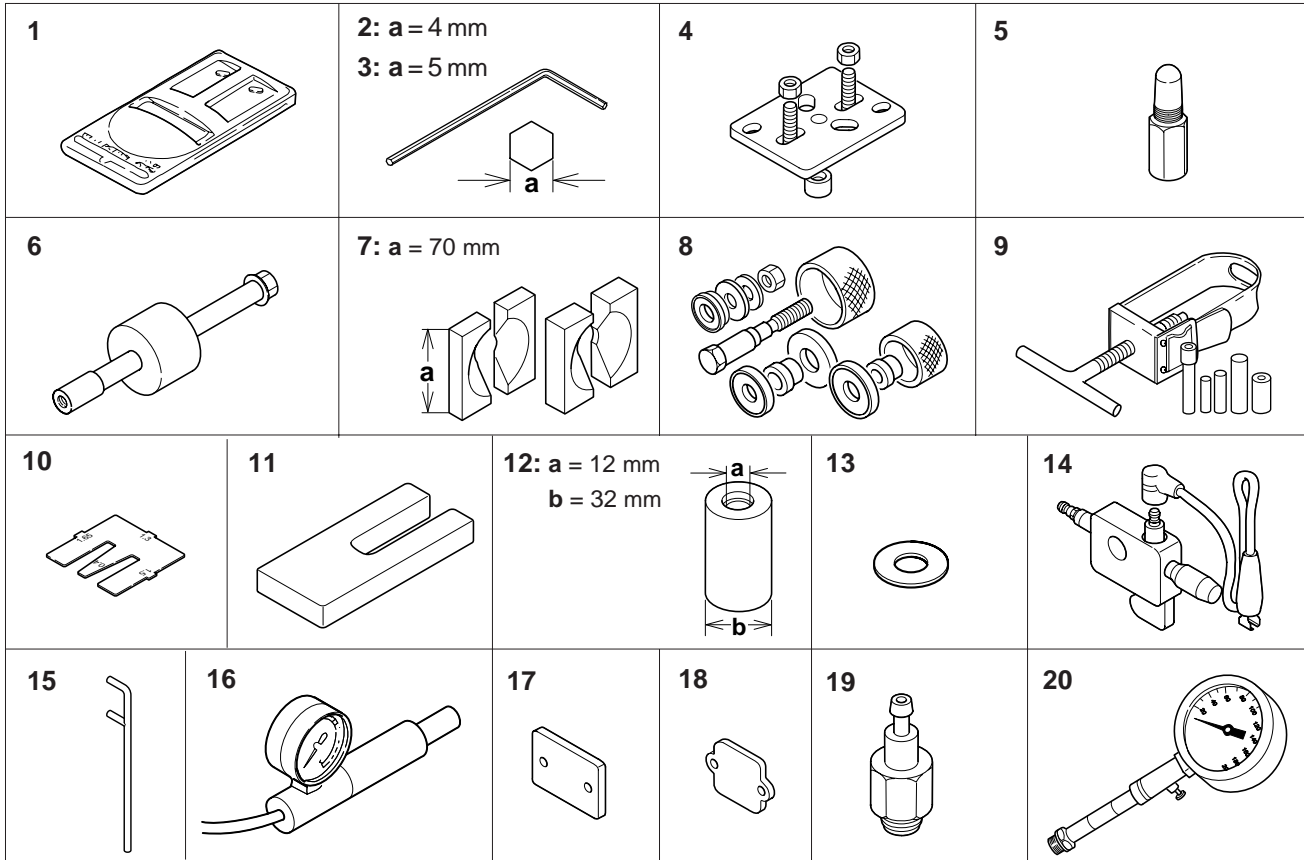

Key	Part Number	Description	Used for:
1	897801-33330	Tachometer PET-1000	Measuring engine speed to adjust carburettor
2	895610-79920	L-hex wrench (4 mm)	Removing and installing hex. socket bolt (M5)
3	895611-79920	L-hex wrench (5 mm)	Removing and installing hex. socket bolt (M6)
4	897501-03938	Puller	Removing flywheel
5	897537-30130	Piston stopper	Locking crankshaft rotation
6	897603-23030	PTO shaft puller	Removing PTO shaft
7	897701-06030	Bearing wedge	Removing ball bearing on PTO shaft / drive gear
8	897701-14732	Bearing tool	Removing and installing ball bearings on crankcase / clutch drum
9	897702-30131	Piston pin tool	Removing and installing piston pin (Use 8 mm dia. adapter and 9 mm dia. guide)
10	897563-19830	Metering lever gauge	Measuring metering lever height on carburettor
11	897719-02830	Piston holder	Making piston steady to remove and install piston / ring
12	897714-24330	Oil seal tool	Installing crankcase oil seal (starter side) / PTO shaft bearings
13	363018-00310	Washer	Installing crankcase oil seal (starter side)
14	897800-79931	Spark tester	Checking ignition system
15	897712-04630	2-pin wrench	Removing and installing pawl carrier
16	897803-30132	Pressure tester	Testing fuel pipes/tank and crankcase leakages
17	897826-16131	Pressure plug	Plugging intake port to test crankcase / cylinder sealing
18	897827-16131	Pressure plate	Plugging intake port to test crankcase / cylinder sealing
19	897835-16131	Pressure connector	Testing crankcase and cylinder leakages
20	91007	Compression gauge	Measuring cylinder compression

2 EMISSION ADJUSTMENT GUIDE

2-1 General adjusting rules

Before starting the unit for adjustment, check the following items.

1. The correct spark plug must be clean and properly gapped.
2. The air filter element must be clean and properly installed.
3. The muffler exhaust port must be clear of carbon.
4. The fuel lines, tank vent and fuel filter are in good condition and clear of debris.
5. The fuel is fresh (> 89 octane : RON) and properly mixed at 50 : 1 with "ISO L-EGD" 2 stroke oil.
6. Two line nylon line head with properly cut lines must be installed for proper engine loading.

2-2 Presetting idle adjust screw and idle mixture needle

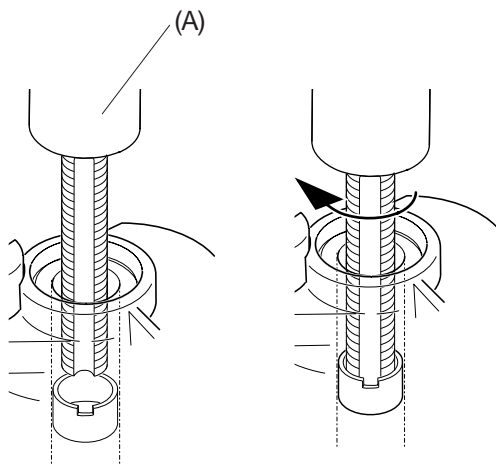

1. Remove the plug from idle mixture needle hole using M2.5 tap (A) as shown.

NOTE : When plug is damaged and left in the hole, use needle or pin-shaped object to scrape.

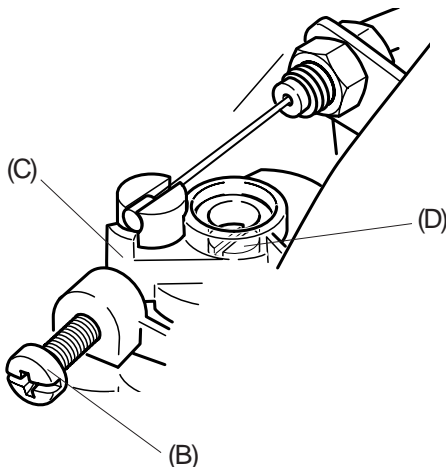

2. Turn idle adjust screw (B) anticlockwise until its tip just touches throttle plate (C). Then turn it in clockwise 4 1/2 turns.

3. Turn idle mixture needle (D) anticlockwise to fully come out until clicking sound is heard. Then turn it clockwise 14 turns.

2-3 Adjusting carburettor

1. Start engine and warm it up well for about 3 - 5 minutes with cycle of 50 seconds WOT (Wide Open Throttle) and 10 seconds at idling.
2. Adjust idle mixture needle and obtain maximum idle speed with 2.5 mm blade screw driver.
3. Set idle speed to the range of 3,300 to 3,800 r/min by turning idle adjust screw.
4. Turn idle mixture needle anticlockwise to reduce idle speed 800 to 1,000 r/min to the final range of 2,300 to 3,300 r/min.

NOTE : Engine speed must be allowed to stabilize a minimum of 20 seconds after each adjustment to assure accurate tachometer readings.

5. Check WOT engine speed. WOT engine speed should be more than 9,500 r/min.

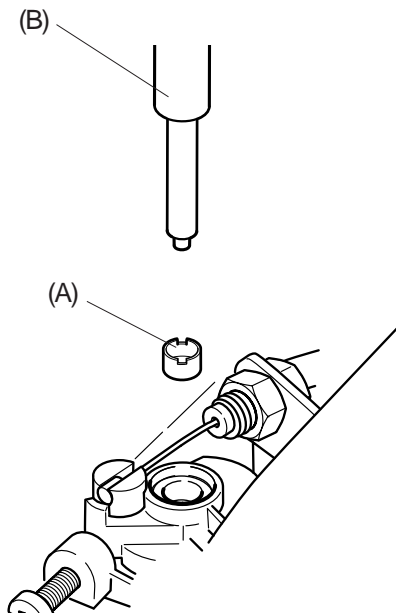

6. After adjusting carburettor, insert and secure plug (A) deep in the needle hole per directive. Spring pin tool (3 mm) 897724-01261(B) is useful to insert the plug.

7. Start engine again and make it sure engine runs at idle speed of 2,200 to 3,400 r/min. Also make it sure cutting device would not turn at engine idle speed.